



## SLC / CLC RetroPAK Controllers

- Replace aging controllers in logical increments
- CAD driven, function block configuration with “Bailey” Function Code and template library
- True peer-to-peer communications
- Robust, highly visible display resistant to effects of temperature and power surge
- Quality detection on all inputs, outputs and internal parameters
- Fits same panel cutout
- Factory duplication of existing SLC or CLC configuration available
- STEAMPAK series for boiler controls



**The Logical Migration**

The SLC/CLC RetroPAK is a strategy to help Loop Command users migrate to current technology, and includes the features that made these controllers so popular, especially for steam and power generation. In addition it offers a host of other powerful features and up-to-date communication strategies that make RetroPAK the logical choice for replacing aging SLC and CLC controllers.

**HARDWARE PLATFORM**

The basis of the SLC/CLC RetroPAK, MOD 30ML, uses state-of-the-art surface mount technology. Like the SLC and CLC, the basic hardware platform includes the carrier board, CPU, display assembly, and terminations. The instrument uses 64K bytes of non-volatile RAM not only to store the configured database, but to back up all current process and operating parameters.

The RetroPAK controller fits into the same panel cutout as the CLC and SLC controllers. The actual housing of the RetroPAK controller requires less panel depth. Field wiring is simplified by removable termination blocks.

The display assembly is well suited to the environment of boiler control applications, and can withstand power dips and recovery surges. It is also less susceptible to temperature rise than older technologies.

**PROCESS I/O**

The RetroPAK controller provides the same I/O complement as the CLC and SLC controllers:

- 4 analog inputs (two universal and two current 4-20mA) each with independent, isolated transmitter power supply
- 2 milliamp outputs
- 3 digital inputs (2.5 - 28Vdc)
- 4 digital outputs (5 - 60V dc)

Two of the standard analog inputs are universal, so low-level inputs such as thermocouple and RTD can be accommodated without ordering extra options.

**COMMUNICATIONS**

Serial communication and Peer-to-Peer capability are standard features of every controller. The RetroPAK controller includes a peer-to-peer Instrument Communication Network (ICN) and Modbus RTU over RS-485, on two separate communication ports. This separates control data from information and operational data being sent to a PC or console.

The Instrument Communication Network (ICN) provides peer-to-peer communication with other RetroPAK, SteamPAK, or MOD 30ML controllers. It uses a token-passing ring protocol which guarantees every instrument access to the bus within a determinate amount of time (nominally 250ms). If an instrument on the bus should cease to communicate, its peers generate diagnostic alarms but continue to operate with the last good data received.

A second serial network is provided using a plug-in module for RS-485 Modbus RTU. This network is independent of the ICN. Direct connection to a PC using RS-485 eliminates the need for an intermediate device such as the CIC01. For systems that include a LAN-90 console, MicroMod's Micro-PWC software is a logical upgrade path to the Windows environment.

Many CLC and SLC controllers are part of the larger Infi90 control system. Although the RetroPAK controllers do not use the Bailey Modulebus communications protocol, they can be integrated with the system using either the Field Device Interface, or an OPC Server communicating with the Conductor NT software. An optional Ethernet modem is available to bring the data from the RetroPAK controllers onto the plant Ethernet network.

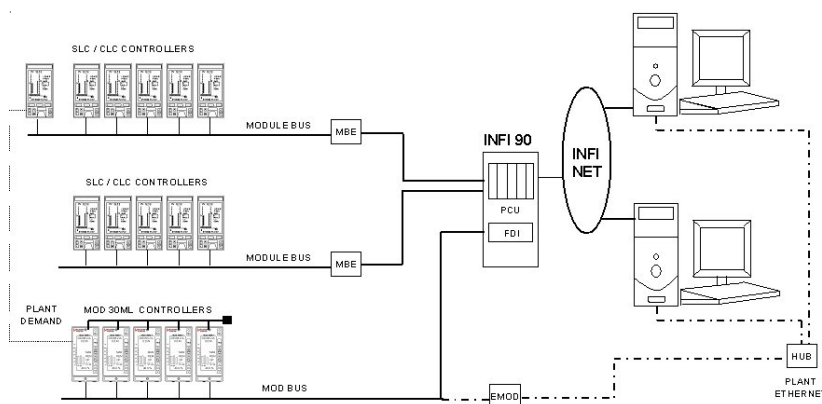

## OPERATOR DISPLAY

The bright, highly visible vacuum fluorescent front screen provides a wide viewing angle and a high level of information for ease of operation.

### Standard Operating Screens

In normal operating mode each screen shows three bargraphs representing Process, Setpoint, and Output. Three eight-character alphanumeric lines indicate the Loop Tag; the numeric process value; and the numeric value of the variable indicated by the Status Indicator (typically Output and Setpoint). Three-character Status Indicators display controller Mode (Auto/Manual), Setpoint status (Local/Re-mote), and the variable whose value is being displayed on the bottom line of the screen. The up/down arrow keys are used for changing this value. The standard ramping method allows the operator to select the desired value without any overshoot.

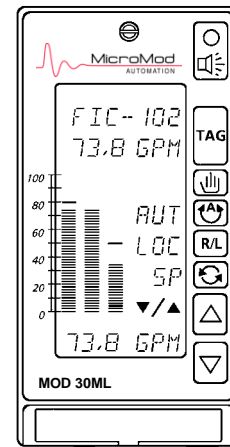

### User-definable Alarm Screens

Active process and diagnostic alarms are indicated by the flashing red LED on the keypad, and/or flashing display and audible alarm. Complete alarm information including value, alarm type (high, low, deviation etc.) and user-configured label can be viewed by pressing the Alarm key. A Return key allows the operator to switch directly from the Alarm display to the operating display for the variable in alarm condition. Any number of alarms may be configured for an analog or a digital signal, and there is no limit to the total number of alarms per controller.

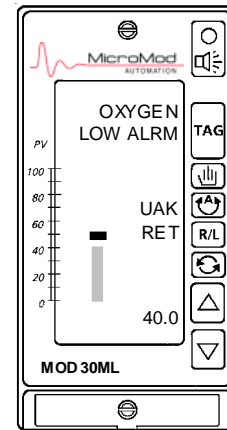

### Tuning and Commissioning Screens

Control loops are tuned through Tuning displays, accessed by a user-specified password. Standard tuning parameters, recipe parameters, and X, Y table coordinates can be entered through the faceplate, without the need for a handheld terminal or computer. The controller also displays raw input values for commissioning and startup, as well as detailed diagnostic information before and during normal operation. An Event Queue of up to 1024 entries is maintained by the instrument, and can be viewed from the front panel.

### Custom Displays

In addition to standard displays, application-specific screens can be configured for sequence and batch operations, discrete device operation, recipe selection, and multiple variable indication. Keys can be assigned different functions on a per-display basis through a script language. The number of screens per controller is limited only by operator preference and plant operating philosophy. It is also possible to configure "hidden" screens accessed through a tuning-level password.

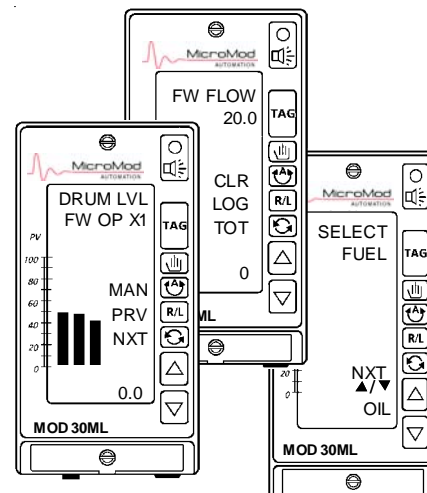

## SAFETY AND SECURITY

The RetroPAK goes over and above the features provided by the SLC and CLC controllers for protecting the process and ensuring continued safety and operation.

### Signal Quality Detection

All inputs and outputs have quality detection and an associated alarm bit, allowing the controllers to change mode based on signal quality for strategies such as manual override. In addition, all internal signals can be configured for quality checking.

### Recovery after power failure

Power fail/recovery settings are available for every parameter, so that outputs, steps, control modes and setpoint values assume a known good value, either 'previous' or user-configured, after a power outage. In addition, warm- and cold-start options allow different settings depending on a user-specified time period before power is restored. The configured information is stored in the controller's non-volatile memory. This feature can accelerate the restart process and significantly reduce downtime.

### Failsafe output settings

The user also has the option to select failsafe values, either 'previous' or a user-determined value, on all outputs should the controller I/O lose communication with the CPU. These values are independently configurable for each output, and reside in the modules. The Expansion I/O also allows failsafe settings.

### Single-point isolation, Short-circuit protection

Inputs, outputs and built-in communications are individually isolated, channel-to-channel and channel-to-ground. This helps eliminate propagation of noise and spikes on signal and power lines when the controller is properly grounded. Each I/O point includes short-circuit and cut-wire detection with associated diagnostics, and a digital flag that can be used to initiate alternate control logic such as safe shutdown. Out-of-range and quality diagnostics are also associated with each point.

### Backup of database and tuning parameters

The Portable Memory Module, available as an option, contains a backup copy of the controller's configured database. When installed on an operating instrument, it is updated every 50ms with current process parameters including PID and sequence output values and status, tuning values, current sequence step, calculation results etc. Continuous checksums ensure against corruption of Memory Module data.

In the event an instrument needs replacement, the Memory Module can be installed on the new instrument for instant, as-you-were recovery of operations. The Memory Module can also be write-protected so that a known good database can be downloaded either manually or on power-up.

### Output Bypass

It is sometimes necessary to bypass the controller CPU and directly control the output to the valve. The optional Output Holder mounts in series with the controller, and during normal operation the controller's output is passed through to the valve. Should the controller's CPU or output fail, the Output Holder automatically maintains the output signal. Visual indication and up/down arrow keys allow direct manipulation of the output, even when the controller is removed from service. Direct output control does not depend on having a powered controller in place.

## CONFIGURATION

The configuration software for the RetroPAK controllers, Visual Application Designer, provides the standard factory templates used in the CLC and SLC. These ready-to-use templates are easily downloaded to the controller from a PC or laptop. Final ranges and tuning parameters are entered from the front panel. In addition, the Bailey Function Code blocks are included in the software library. Very little knowledge of the Visual Application Designer package is required to create the same types of control strategies used in the SLC and CLC.

All the Function Codes and native controller function blocks are re-useable. The RetroPAK controller has four times as much configuration space, accommodating even the most complex applications including burner management.

The Visual Application Designer software provides a Windows-based environment for creating, editing, downloading, documenting and debugging controller databases. It provides automatic, on-screen documentation of the configuration, including signal source and destination. On-line, context sensitive help is available for each block. Live debug and runtime facilities allow on-line verification of the database and process logic, and trend windows simplify loop tuning at commissioning time. There is also a set of drawing tools that can be used to construct runtime displays or place dynamic process symbols next to the algorithm blocks in the configuration for easier debugging, without using a separate HMI package. Automatic report generation includes tabular reports containing all blocks in the system, their internal parameters, and all connections, as well as graphical reports showing the database diagram exactly as it is drawn.

## DATABASE DUPLICATION

The SLC/CLC RetroPAK includes the option for MicroMod application engineers to duplicate the database configuration of your existing SLC or CLC controller in the new RetroPAK controller. If this option is selected, you do not to purchase or learn the Visual Application Designer software. This option requires complete documentation of the existing controller database, or a copy of the configuration file, along with architectural and wiring diagrams. MicroMod Automation will provide you with a fully configured and documented RetroPAK controller, including wiring and startup instructions.

## BEYOND THE SLC

The controller that forms the basis for the SLC RetroPAK -- the MOD 30ML -- has the power to take your control system beyond the original SLC or CLC installation and optimize your application for today's control requirements. A wide selection of digital and analog single-point I/O modules, together with additional PID control capability, sequence and logic functions, math calculations and more allow many strategies to be implemented in a fewer number of controllers, saving money and space. For example, MicroMod's standard package for fully-metered combustion controls uses just three MOD 30ML controllers and provides added safety features.

## STEAMPAK SERIES

For standard boiler control applications, MicroMod offers pre-engineered, pre-configured packages that perform all the functions of the SLC or CLC with less hardware, less engineering and less startup time. Each package is designed by our boiler experts to meet the needs of the majority of installations. One simple model number includes a preconfigured controller, detailed installation instructions specific to the application, and a clear operating guide tailored to the individual loops. Several packages also include pre-ranged field instruments.

- DRUMPAK – two and three-element drum level control packages
- TRIMPAK – dual fuel combustion control upgrade package with O2 trim for jackshaft boilers
- METERPAK – dual fuel, fully metered combustion control system with cross-limits, furnace pressure control and O2 trim in just three controllers. An option for a separate Boiler Master is also available.

For more information see Specification Sheet S-STEAMPAK-DRUMPAK, S-STEAMPAK-TRIMPAK, and S-STEAMPAK-METERPAK. Or visit our website at [www.micromodautomation.com](http://www.micromodautomation.com)

**Feature/Function Comparison**

SPECIFICATION	CLC	SLC	RETROPAK
<b>Analog Inputs</b>			
Number available	4	4	4
High Level	Yes	Yes	Yes - 2 universal
Stated accuracy	+/- 0.2%	+/- 0.2%	+/- 0.2%
Signal range	1 - 5Vdc / 4-20mA	1 - 5VDdc / 4-20mA	0 - 20mA (two of four inputs are universal)
Isolation	No	Yes	Yes - 250V rms
24Vdc Loop Power	Yes	Yes	Yes
Short circuit protection	Yes	Yes	Yes
<b>Direct Temperature Inputs</b>			
Number available (in place of std. inputs)	0	2	2
Isolation	-	Yes	yes
<b>Digital Inputs</b>			
Number available	3	3	3
ON/True/Closed/"1" range	10-24Vdc	10-24Vdc	4 - 16Vdc
OFF/False/Open/ "0" range	0-1.7Vdc	0-1.7Vdc	0 - 1 Vdc
Maximum current	4.7mA	4.7mA	45 mA
Minimum on/off time	500 ms	500ms	0.1 ms
<b>Frequency/Pulse Inputs</b>			
	0	1	0
<b>Analog Outputs</b>			
Number available	2	2	2
Stated accuracy	+/- 0.2%	+/- 0.2%	+/- 0.2%
Isolation	No	No	Yes
Max. load resistance (current)	700 ohms	700 ohms	1000 ohms
<b>Digital Outputs</b>			
Number available	4	4	4
Rated (resistive load)	24Vdc@80mA	24Vdc@80mA	5 - 60Vdc @ 1 Amp
Off state leakage current	10 microA	10 microA	max: 1mA @ 60Vdc Typical: 0.5 microAmp @25Vdc / 25 deg. C
Type	opto-isolated open collector	opto-isolated open collector	opto-isolated open collector

**Feature/Function Comparison**

<b>SPECIFICATION</b>	<b>CLC</b>	<b>SLC</b>	<b>RETROPAK</b>
<b>Power Supply Options</b>			
120Vac	90-130Vac 50/60 Hz	90-130Vac 50/60 Hz	85-250Vac and 50-350Vdc 50/60Hz
240Vac	180-260Vac 50/60Hz	180-260Vac 50/60Hz	included above
24Vdc	Yes	Yes	Yes
<b>Physical Characteristics</b>			
Faceplate dimension	72x144mm	72x144mm	72x144mm
Depth	456mm (17.95 in.)	425mm (16.75 in.)	400mm (15.75 in.)
Weight	9 lbs	8 lbs	6 lbs
Display functionality	3-bar	Graphic	3 bar programmable
Display technology	Gas plasma	Vacuum fluorescent	Vacuum fluorescent
Engineering units	Yes	Yes	Yes
<b>Functional Characteristics</b>			
Configuration Space	255	1064	64Mbytes
External device required	Yes (handheld)	No	Yes - for configuration (PC) Tuning - no (front face)
Serial link/data link	Bailey Module bus	Bailey Module bus	Modbus RTU RS-485
Peer-to-peer network	Yes - Bailey Modulebus	Yes - Bailey Modulebus	Yes - ICN
Max. # of networked units	32	32	16
Self-tuning	No	Smith Predictor or Custom algorithms	Adaptive tuning
On-line readjustment of PID parameters	No	Yes	Yes
<b>Control Functionality</b>			
Number of PID loops	2 (cascade)	2 (cascade)	6 independent or 4 cascade
Math calculation	Yes	Yes	Yes
Sequence	No - requires external device	No - requires external device	Yes
Logic	Yes	Yes	Yes
Totalizer	Yes	Yes	Yes
Timer	Yes	Yes	Yes
Re-usable function codes	Yes	Yes	Yes - 4096 of each
Quality Check	Yes - function code	Yes - function code	Yes - all hardware & software inputs & outputs

## GENERAL SPECIFICATIONS

### PID Loops

six single or four cascade

### Execution Time

Built-in I/O: 100mSec.

Analog Module I/O: 150mSec. nominal

Digital I/O: 50mSec.

### Operating Range

85-250V rms, 50-400Hz

### Fuse

2.5 Amps (ac), 4.0 Amps (dc)

### Power Consumption (120V rms, 60Hz, Full load)

50W maximum

### Data Retention (Non volatile RAM memory and Portable Memory Module)

Typically 10 years with instrument unpowered

### Operating temperature

0 to +50°C

### Storage Temperature

-40 to +75°C

### Humidity

5 to 95% RH, noncondensing

### Open Input Fault Detection

Controller recovery is user configurable for all inputs using Visual Application Designer

### Fault Output

Built-in outputs - last value or 0%

Module outputs - user defined between 0 and 100%

### Network

Instrument Communication Network (peer-to-peer)

Maximum distance: 2000 ft.

Maximum number of devices: 16

Modbus RS-485:

Maximum distance: 4000 ft.

Maximum number of devices: 255

## PHYSICAL SPECIFICATIONS

### Height

Bezel - 5.69" (144.5 mm)

Panel cutout - 5.47" (138.9 mm)

### Width

Bezel - 2.87" (72.9 mm)

Panel Cutout - 2.69" (68.3mm)

### Safety Approvals

FM Approved and CSA Certified Class I, Division 2, Groups A, B, C, D

### Depth

Behind the panel - 15.75" (400 mm)

Front of panel - 1.13" (28.7 mm)

### Weight

6.0 lbs.

### Mounting

Instrument mounts directly in a panel

## I/O PERFORMANCE SPECIFICATIONS

### Built-In Universal Analog Inputs and Outputs

#### Analog Inputs (2)

<b>Transmitter power</b>	Isolated 24Vdc, one per input				
<b>Range/Span</b>	<b>Configured as:</b>	<b>Min</b>	<b>Max.</b>	<b>Min span</b>	<b>Impedance</b>
	Millivolt	-10	120	10	10M $\Omega$ min
	Volts	0	6.0	0.1	10M $\Omega$ min
	Milliamps	0	22	1.0	100 $\Omega$ nominal
	Resistance	500 ohms (20 $\Omega$ min. with 3.9K $\Omega$ resistor added)			

#### Temperature Input Linearization

Thermocouple – per NBS 125 and IEC 584 standards  
 RTD – per IEC751 and DIN43760 standards

Measuring Range Limits – Thermocouple or RTD	$^{\circ}$ F Lower	$^{\circ}$ F Upper	$^{\circ}$ C Lower	$^{\circ}$ C Upper
Type B	392	3308	200	1820
Type E	-328	1832	-200	1000
Type J	-346	1400	-210	760
Type K	-328	2501	-200	1372
Type N	32	2372	0	1300
Type R&S	32	3214	0	1768
Type T	-430	752	-257	400
RTD	-328	1562	-200	850

Note: Performance accuracy is not guaranteed below 752 $^{\circ}$ F (400 $^{\circ}$ C) for Type B thermocouple. RTD, 3-wire platinum, 100 ohm per DIN 43760 (IEC751), with range of 0-430 ohms (normal) or 0-55 ohms (low).

<b>Common Mode</b>	45Vdc
<b>Isolation</b>	Full galvanic isolation using transformers and opto isolators

#### Analog Outputs (2)

<b>Range</b>	0 to 22mA non-isolated with user set span (minimum 1mA)
<b>Load</b>	22mA at 1000 ohms maximum

## Modular Inputs and Outputs

### Isolated Current Input with 2-wire transmitter power

Range	4 to 20mA
Low limit	0 mA
Upper limit	27.5 mA
Input Resistance	50 ohms
Noise filter	3db at 5 Hz
Resolution	14 bits
Sensitivity	1 $\mu$ A
Accuracy	0.2%
Isolation	250V rms
Normal mode rejection	40 db at 60 Hz minimum

### Isolated Digital Inputs

Input voltage ranges	2.5-28Vdc
Max Logic Low Input	1V
Max Input current	30mA
Response time	1.5 msec
Input resistance	900 ohms

### Isolated Digital outputs

Output voltage ranges	5-60V dc
Max Output current	1A
Response time	0.75 msec

**Ordering Instructions:**

1. Provide end-user name and contact information
2. If Custom Configuration services are selected, provide original database documentation or file for SLC or CLC controller
3. ViZapp software is required to configure RetroPAK controllers (not required if Custom Configuration services are selected)
4. Rebate certificate will be shipped with the RetroPAK controller. Mark the SLC or CLC serial number on the certificate and return with the used controller.

Base Controller includes: 4 analog inputs; 2 analog outputs; 3 digital inputs; 4 digital outputs; serial communications and peer-to-peer communications

SLC / CLC RetroPAK Controller	SLCRETRO	-	___	-	___
<b>Base Controller</b>	SLCRETRO				
<b>Power Supply</b>					
24V dc			0		
85 to 265V ac			1		
<b>Custom Configuration Services</b>					
None (requires Configuration Development Software)					000
Duplicate existing CLC Controller configuration ( <i>Note 1</i> )					CLC
Duplicate existing SLC Controller configuration ( <i>Note 1</i> )					SLC

**Note 1:** Database documentation and/or configuration file for existing controller must be provided  
 \* \$2,230 after Rebate

	VIZAPP	-	SLC	-	DEV	-	___	-	___
<b>Configuration Development Software</b>									
<b>Communications Interface</b>									
Extended Modbus OPC Server Included			SLC						
<b>Functionality</b>									
Development					DEV				
<b>Software Key Type</b>									
Parallel Port							PAR		
USB (Universal Serial Port)							USB		
<b>Extended Support Services (ESS)</b>									
None									000
One Year Technical Support & Version Updates									ESS

<b>ACCESSORIES</b>	
ICN Termination Assembly (one required per peer-to-peer network)	2030FZ00001A
Portable Memory Module (optional)	2010PZ10000A
Output Holder / Manual Loader (see Specification Sheet S-MOD-Accessories)	1750NZ10001A

**Mounting Dimensions**

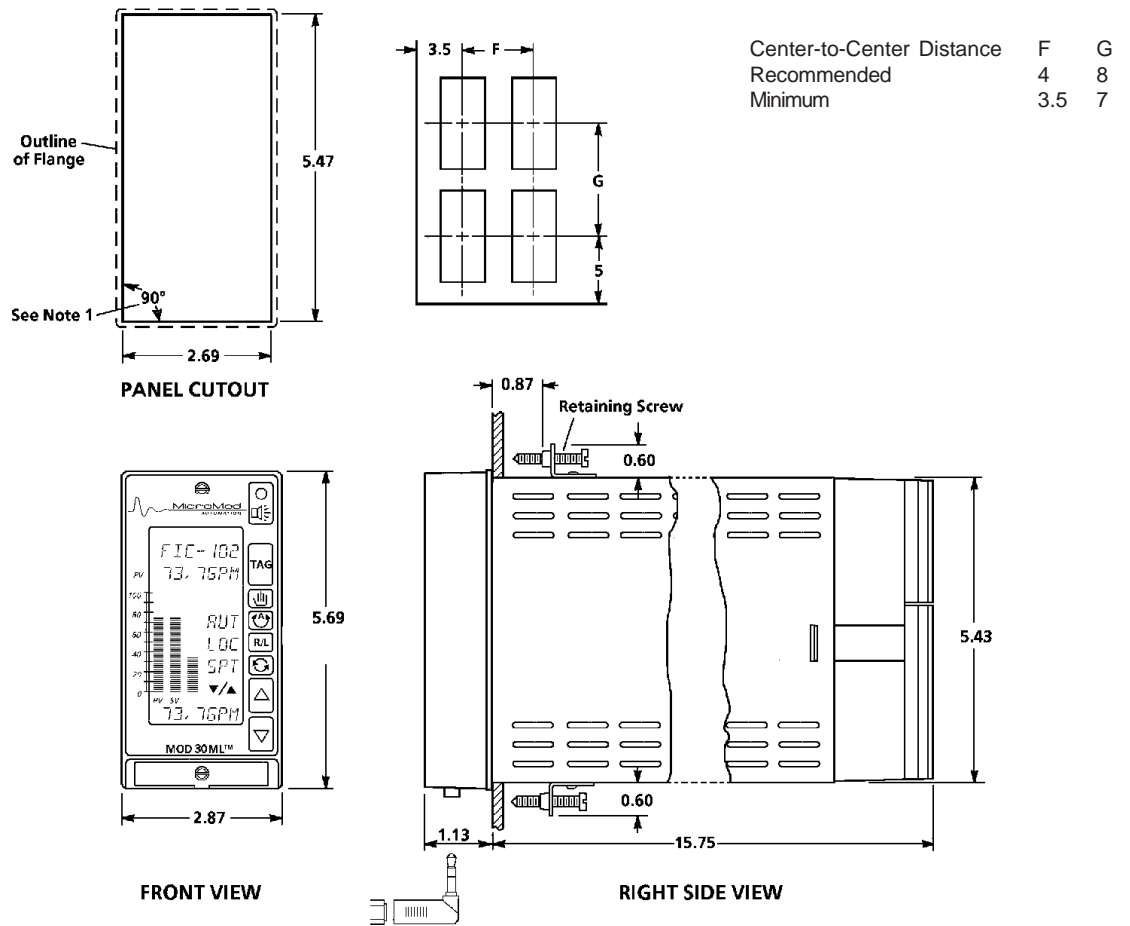

1.5 inch (38.1mm) clearance for optional communications jack.

Inches	mm	Inches	mm
0.6	15.2	5.43	137.9
0.87	22.1	5.47	138.9
1.13	28.7	5.69	144.5
2.69	68.3	7	177.8
2.87	72.9	8	203.2
3.5	88.9	15.75	400
4	101.6		

*Note:*

*When mounting housing in panel cutout or rack and panel mounted bezel, turn retaining screws until point of screw touches rear of panel or bezel. Overtightening of retaining screws will distort housing. Housing must be square after retaining screws are tightened.*

---

[www.micromodautomation.com](http://www.micromodautomation.com)

The Company's policy is one of continuous product improvement and the right is reserved to modify the information contained herein without notice.

Printed in USA (October 2005)

© MicroMod Automation, Inc. 2004



---

**MicroMod Automation, Inc.**  
75 Town Centre Dr.  
Rochester, NY 14623 USA  
Tel: (585) 321-9200  
Toll Free: 1-800-480-1975  
Fax: (585) 321-9291  
Email: [sales@micmod.com](mailto:sales@micmod.com)

S-RETROPAK-SLC\_CLC